



Smart solutions.
Strong relationships.

LT Motors

SAFE AREA MOTORS

Cat No: LTM/Cat/01/Dec.2009



AVANTHA
GROUP COMPANY





TEFC Motors

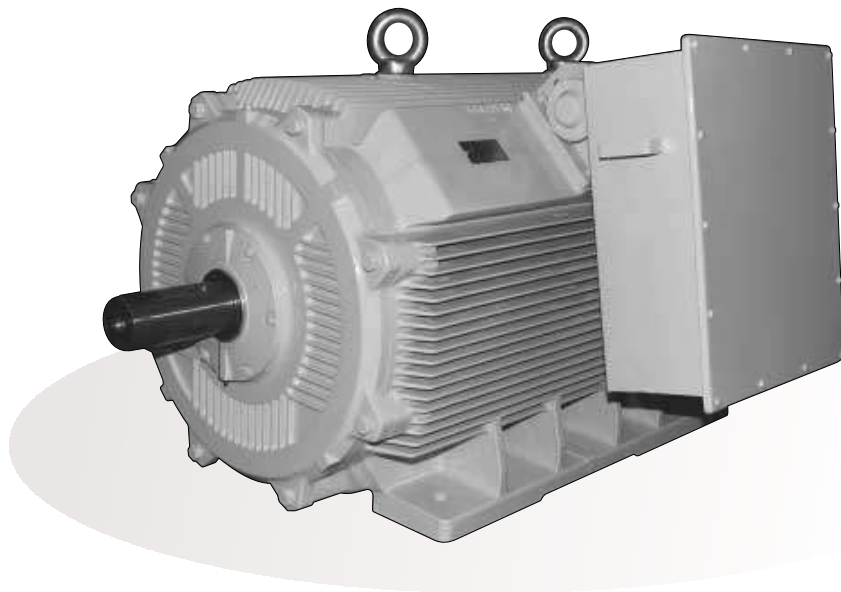

0.18 kW to 450 kW
From 63 to 400 Frame
Frame 450 under development



ENERGY EFFICIENT MOTORS LEVEL 2

TEFC CAGE MOTORS

- Energy Efficiency level 2 as per IS:12615

- Energy Efficiency as per CEMEP Standards prevalent in Europe

- Sleek and compact design, Improved aesthetics

- 'V' seal arrangement up to 355 frame - Easier assembly of bearing housing

- Integral bearing cover with endshield up to 225 frame

- Larger terminal box for accommodating bigger Aluminium cables

- Sophisticated CNC Machines, Most Advanced Manufacturing Technology & Test Plant - Improved reliability.

STANDARD SPECIFICATIONS

RANGE	0.18 kW to 400 kW (FRAME 63 to 400) Multi speed options are also available
VOLTAGE	415 V +/- 10 %
FREQUENCY	50 Hz +/- 5 %
COMBINED VARIATION	+/- 10 % (ABSOLUTE SUM)
INSULATION	Class 'F' (Temp. rise limited to class 'B') as standard
MOUNTING	Horizontal foot mounting (B3) as per IS :1231.
AMBIENT / TEMPERATURE RISE	50 ° C / 70 ° C
DEGREE OF PROTECTION	IP55 AS PER IS: 4691



BEARINGS & TERMINAL BOX DETAILS

BEARING SIZE CHART

FRAME SIZE	DE BEARING	NDE BEARING
SD63	6201ZZ	6201ZZ
SD71	6203ZZ	6203ZZ
SD/ND80	6204ZZ	6204ZZ
SD/ND90S/L	6205ZZ	6205ZZ
SD100L	6206ZZ	6206ZZ
ND100L	6206ZZ	6205ZZ @
SD/ND112M	6306ZZ	6205ZZ @
ND/NC132 S/M	6308ZZ	6208ZZ
SD132 S/M	6308ZZ	6305ZZ
ND160M/L	6309 2RS	6209 2RS
ND180M	6310 2RS	6210 2RS
ND200L	6312 2RS	6212 2RS
ND225M	6313 2RS	6213 2RS
ND250M - 2P	6314	6314
ND250M 4P UP	6314	6314
ND280S/M 2P	6314	6314
ND280S/M 4P & UP	6318	6318
ND315S/M/L/LX 2 P	6315	6315
ND315S/M/L/LX 4P & UP	6319	6319
ND355S/M/L/LX 2P	6316	6316
ND355S/M/L 4P UP	6321	6321
ND355LX 4P UP	6322	6322
ND400LX 2P	6318	6318
ND400LX 4P UP	6322	6322
DW132	6308	6208

@ For single shaft extension. For double shaft extension-Bearing Size-6206 ZZ.

TERMINAL BOX :

TEFC FRAME	MAXIMUM CABLE SIZE		NO. OF MAIN TERMINALS	TERMINAL STUD SIZE		BSC ENTRY	
	DOL	STAR/DELTA		MAIN	EARTH	NOS.	SIZE
SD63-SD71	4CX4mm ²	-	6	M5	M4	1	¾"
SD80 *	4CX4mm ²	-	6	M5	M4	2	¾"
ND80	4CX4mm ²	-	3	M5	M4	1	¾"
ND90S-ND132M	4CX10mm ²	4CX10mm ²	6 #	M6	M5	DOL-1 S/D-2	1"
SD90S-SD100L	4CX10mm ²	-	6	M6	M5	1	1"
NC132S/M	4CX10mm ²	4CX10mm ²	6	M6	M5	DOL-1 S/D-2	1"
ND160-ND200	3CX50mm ²	2X3 C X35mm ²	6	M6	M8	2	1"
ND225 TO ND280	3CX120mm ²	2X3C X95mm ²	6	M8	M12\$	2	1 ½"
ND315S/M/L	3CX300mm ²	2X3 C X 240mm ²	6	M12	M12	2	2"
ND355L/LX	3C x 400 mm ²	2 x 3C x 300 mm ²	6	M16	M12	2	2.5"

* INTEGRAL TERMINAL BOX

3 LEADS UPTO 2.2 kW2 P/4P & 1.5 kW 6P/8P and below, 6 leads for 2.2 kW 6P/8P & above (For ND Frame only)

\$ M12 FOR 250/280 FRAME & M8 FOR ND225 FRAME



NOISE & VIBRATION LEVELS

NOISE LEVEL

The noise level of the motors is restricted to the levels specified in IS 12065. Table below gives the noise level as per IS 12065 **Limiting Mean Sound Power Level L_{w} in dB (A) for Airborne noise emitted by Rotating Electrical Machines.**

Protective Enclosure		IP 44	IP 44	IP 44	IP 44	IP 44	IP 44
Rating kW (or kVA)		Rated Speed (rev. /min.)					
ABOVE	UPTO	960 & below	961 to 1320	1321 to 1900	1901 to 2360	2361 to 3150	3151 to 3750
		Sound Power Level dB (A)					
-	1.1	76	79	80	83	84	88
1.1	2.2	79	80	83	87	89	91
2.2	5.5	82	84	87	92	93	95
5.5	11	85	88	91	96	97	100
11	22	89	93	96	98	101	103
22	37	91	95	97	100	103	105
37	55	92	97	99	103	105	107
55	110	96	101	104	105	107	109
110	220	100	104	106	108	110	112
220	630	102	106	109	111	112	114

Note 1: IP 44 corresponds generally to totally enclosed fan-cooled, closed air circuit air-cooled & similar enclosure (see Is-4691)

VIBRATION.

The motor is said to be in state of vibration if any part of it experiences displacement in any direction. Standard motors comply with normal class of vibration depending on severity as per IS 12075. "Measurement & evaluation of vibration of Rotating Electrical Machines". The limits of vibration levels are given below.

VIBRATION LEVELS:

LIMITS OF VIBRATION SEVERITY IN ROTATING ELECTRICAL MACHINES
MEASURED IN STATE OF FREE SUSPENSION *

Shaft height H, mm	56 to 132		160 to 225		225	
Range of speed	600 to 1500	Above 1500 & Upto 3000	600 to 1500	Above 1500 & Upto 3000	600 to 1500	Above 1500 & Upto 3000
Class of vibration Severity	RMS Value of Vibration Velocity, mm/s					
Normal	1.8	1.8	1.8	2.8	2.8	4.5
Precision A	0.71	0.71	0.71	1.12	-	-
Precision B	0.45	0.45	0.45	0.71	-	-
Precision C	0.28	0.28	0.28	0.45	-	-

* The vibration may be determined in rigid mounting condition but the value of vibration severity shall be agreed by a special agreement between the manufacturer & the user.

EFF Level 2



SPECIAL DESIGNS OFFERED

ELECTRICAL	MECHANICAL
Non Standard Voltage And Frequency Variation	Non Standard Mounting Dimensions
Duel Voltage (1:2 or 1: $\sqrt{3}$ Ratio) Triple Voltage (1: $\sqrt{3}$: 2 Ratio)	Special shaft Extension
Inverter fed Supplies And AC Variable Speed drives	Double shaft Extension
Multispeed Motors Upto 4 different speeds Motors	Separately Ventilated
Energy Efficient Motors	Low Vibration & Noise Level
High Slip Motors	Shock Grade Motors
Motors For frequent starts/stops/reversals (e.g. crane duty)	Motors for Hazardous areas
Torque Motors	Motors For Dust Laden Atmosphere
High Frequency Motors	Brake Motors
Textiles Motors	Canopy for horizontal mounting motors
10,12,16,18,24,32 Pole Motors	Special Bearings like Thrust Bearings
Special Performance Requirements	Tacho Mounting
Class H insulated Motors	Non Standard Paint Shade and Painting Procedure for required Dry Film Thickness
Motors With Service Factor	Fabricated Steel Enclosure Alternate Terminal Box Position
Slipring Motors with Bar-wound rotors for Frames 280 to 400	Special Shaft Material
Motors for operation on Variable Frequency Drive - Refer note on next Pages	Stainless Steel/ Brass Hardware Accessories like Resistance Temperature Detectors, Bearing Temperature Detectors, Thermocouples, Plug & Socket
	Custom Size Fabricated terminal box & Terminal Arrangements.

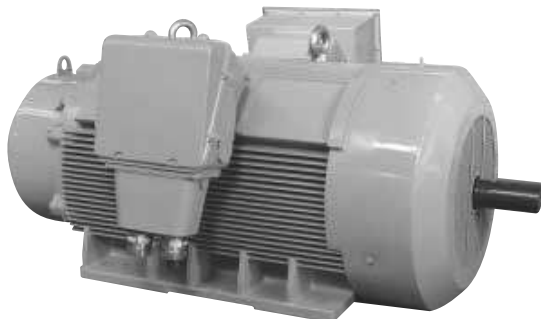



Operating instructions for motors used with variable frequency drives.

Motor terminal voltage transients

Modern drives use power transistors that switch at very high rates. To achieve this, the devices have very fast turn on times that result in voltage pulses with high dv/dt . When such a drive is used with a squirrel cage induction motor, the pulses, in combination with the cable and motor impedance, generate high peak voltages at the motor terminals. These peak voltages are repetitive. They occur continuously and reduce motor insulation system life.

Due to space and surface charge creation within the insulation components, the electric stress is not only defined by the instantaneous voltage itself but also by the peak voltages.

When used with drives, maximum repetitive voltage peaks at motor terminals can be 3.1 times the rated RMS voltage with a rise time not less than 0.1 micro sec. For 415 volt motor, these peaks will be of the order of $415 \times 3.1 = 1286.5$ volts.

Fundamental contributors to peak voltages

It is difficult to determine if a particular drive and cable will cause peak voltages in excess of the motor's insulation capability. There are six fundamental issues that determine the amount of peak voltage that will exist at the motor's terminals: pulse rise time, cable length, minimum time between pulses, minimum pulse duration, transition type (single or double), and the use of multiple motors.

Pulse Rise Time

A certain amount of time is required for the voltage at the drive terminals to transition from low to high. This is called the rise time. A shorter rise time will cause the peak voltage at the motor's terminals to reach a higher value for a given cable length between the motor and the drive.

Cable Length between Drive and the Motor

Distance from the drive to the motor is also important. All motor cables have line-to-line and line-to ground capacitance. Longer the cable, greater the capacitance. Some types of cables, such as shielded cable or cables in metal conduit, have greater capacitance. Spikes occur at the motor terminals because of the charging current in the cable capacitance. Higher voltage (415 V) and higher capacitance (long cables) result in higher spikes. Voltage spikes caused by long cable lengths can potentially shorten the life of the motor.

With modern IGBT drives, the peak voltage begins to occur with a cable length of a few meters and can reach 2 times the control DC bus voltage at a length less than 20 meters. In some cases, however, very long cables (in excess of 130 meters, for example) can result in a situation where the peak voltage does not decay quickly enough. In this case, the peak voltage can be more than 2 times the control DC bus voltage.

Minimum Time between Pulses and Minimum Pulse Duration

An adjustable frequency drive creates, average voltage changes by varying the width of the pulses it produces and the time between them. The peak voltage is potentially at its worst, when time between pulses is at the minimum for the drive and the length of the pulse duration is at the minimum. The minimum time between pulses is most likely to occur at high peak or high output voltages and during transient conditions, such as acceleration and deceleration. Minimum pulse width is most likely to occur at low output voltages. If the time between pulses or the minimum pulse duration is less than three times the resonant period of the cable (0.2 to 2 μ s for industrial cable), higher peak voltages will occur. The only way to be sure this condition does not exist in any particular drive is by measuring the pulses directly or by contacting the manufacturer of the drive.

Transition Type

Each of a drive's three output phases is capable of being switched. Generally, only one of the three phases is switched at any given instant. This situation is called a single transition. Some drives will switch two phases simultaneously. This is referred to, as a double transition. The result is a line-to-line polarity reversal with twice the voltage excursion as that of single transition. This causes higher peak voltage at the motor's terminals. Some drives perform double transitions only during transient conditions such as acceleration and deceleration. Double transitions are generally found in old drives and are not widely used today. The only way to be sure a drive does not perform double transitions is by measuring the pulses directly or by contacting the manufacturer of the drive.

Multiple Motor

If more than one motor is connected to a drive, there can be higher peak voltage due to reflections from each motor. The situation is made worse when there is a long length of cable between the drive and the common connection of motors.

Switching Frequency

Many PWM drives provide for convenient user adjustment of the switching frequency. This frequency can be adjusted over a range as broad as 500 Hz to 20 kHz. The choice of switching frequency is significant because it defines the number of peak voltages that will be occurring at the motor in a certain amount of time. The higher the switching frequency, the greater the number of peak voltages and their magnitude that will be stressing the motor's insulation system.

Temperature rise

When a motor is used with a variable frequency drive supply, it results in higher winding temperature rise as compared to the temperature rise with fundamental sine wave supply. This is due to additional harmonic losses generated due to harmonics present in the output of drive supply.

All CGL motors are supplied with class F insulation system and class B temperature rise limits for sine wave supply. Hence, with VFD supply, temperature rise will be within class F limits.



However, all consultants specify that the temperature rise of the motor winding is to be restricted to class B limits, with drive supply, even though the motor is wound with class F insulation system.

When we want to meet above condition, the motor needs to be derated. This is to be done at preorder stage.

Earthing for the motor

The output earth conductor to be used as equipment earth point for the motor. Please note, the earthed metal conduit carrying the output power conductors does not provide an adequate earthing for the motor. A separate earth conductor for motor is necessary.

The earth conductor of the drive and motor must be separately grounded. These are not to be loop earthed or connected in series.

Service factor for motors used with drives

Service factor is not applicable for the motors used with drive supply. All customers and specifically compressor manufacturers, should note this point.

To have satisfactory operation of the drive and motor, we recommend

Pulse rise time of the drive to be 0.1 microsec or more.

- Locate drive in such a way that cable length between drive and motor will not exceed 10 meters.

- Use appropriate filters, at drive output, wherever above condition of cable length cannot be met. The filters can be output reactor / dv/dt filter/ sinusoidal filter / motor termination unit.
- Cable length between drive and filter must be less than 3 meters.
- Switching frequency to be 5 kHz (Check for magnetic noise required)
- As far as possible, use integrated drive and motor combination. When using multiple motors on single drive, output chokes recommended.
- All parameters needed for setting the converter must be taken from the motor rating plates. The most often needed parameters are:
 - Motor nominal voltage
 - Motor nominal current
 - Motor nominal frequency
 - Motor nominal speed
 - Motor nominal power
- Voltage THD of the drive output shall be less than 5% to avoid excessive temperature rise beyond class F limits.
- Temperature rise for F class motor will be F class. Alternately, to restrict the temperature rise to class B limits, derate the motor by 12 to 15%.
- Insulated bearing recommended for frames 315 & above. Customers are requested to give specific confirmation on this point, since it attracts special price.
- Proper earthing for the motor and drive

EFF Level 2



PERFORMANCE FIGURES OF TEFC SCR MOTORS EFF LEVEL 2 FOR 50°/70°C

OUTPUT		P O L E	FRAME SIZE	FL RPM	FLC AMPS.	FLT Kg-m	EFFICIENCY (%)			POWER FACTOR			DOL STG.		POT % FLT	GD. ² KGM. ²	NET WT. kg
KW	HP						FL	3/4 LOAD	1/2 LOAD	FL	3/4 LOAD	1/2 LOAD	STG.T % FLT	STG.C % FLC			
0.18	0.25	2	SD63	2700	0.56	0.06	64.0	60.0	52.0	0.70	0.62	0.52	250	500	300	0.001	5.6
		4	SD63	1330	0.58	0.13	64.0	60.0	54.0	0.68	0.63	0.54	200	500	275	0.003	5.6
		6	SD71	900	0.64	0.19	60.0	55.0	48.0	0.65	0.55	0.45	170	400	225	0.004	7.0
0.25	0.33	2	SD63	2700	0.64	0.09	68.0	67.0	63.0	0.79	0.72	0.60	250	500	300	0.001	5.6
		4	SD71	1350	0.79	0.18	68.0	66.0	62.0	0.65	0.60	0.53	200	500	250	0.004	7.0
0.37	0.5	2	SD71	2820	1.00	0.13	70.5	66.0	60.0	0.73	0.70	0.63	275	500	300	0.002	7.0
		4	SD71	1400	1.20	0.26	68.0	66.0	62.0	0.63	0.58	0.51	200	500	275	0.004	7.0
0.55	0.75	2	SD71	2800	1.50	0.19	72.0	70.0	65.0	0.79	0.74	0.68	275	500	300	0.003	10
0.37	0.50	6	SD / ND80	910	1.13	0.40	65.0	63.0	59.0	0.70	0.63	0.50	200	400	250	0.011	17
		8	SD / ND90S	680	1.41	0.53	64.0	60.0	54.0	0.57	0.50	0.40	170	400	225	0.015	22
0.55	0.75	4	SD / ND80	1410	1.44	0.38	73.0	72.0	69.0	0.73	0.67	0.54	200	500	275	0.007	17
		6	SD / ND80	910	1.56	0.59	69.0	66.0	60.0	0.71	0.63	0.50	200	400	250	0.011	17
		8	SD / ND90L	680	1.79	0.79	68.0	65.0	60.0	0.63	0.54	0.40	150	400	225	0.021	22
0.75	1.00	2	SD / ND80	2820	1.72	0.26	75.0	73.0	68.0	0.81	0.73	0.60	250	600	300	0.003	17
		4	SD / ND80	1410	1.81	0.52	77.0	74.0	69.0	0.75	0.68	0.58	200	500	275	0.007	17
		6	SD / ND90S	935	1.99	0.78	73.0	71.0	65.0	0.72	0.65	0.55	200	500	250	0.015	22
		8	SD / ND100L	700	2.62	1.04	70.0	67.0	62.0	0.57	0.51	0.42	175	400	225	0.030	32
1.10	1.50	2	SD / ND80	2820	2.42	0.38	78.0	76.0	71.0	0.81	0.75	0.65	225	600	300	0.004	17
		4	SD / ND90S	1415	2.55	0.76	78.0	76.0	74.0	0.77	0.72	0.64	200	500	275	0.014	22
		6	SD / ND90L	935	2.80	1.15	76.0	73.0	67.0	0.72	0.66	0.54	200	500	250	0.021	25
		8	SD / ND100L	700	3.54	1.53	72.0	69.0	65.0	0.60	0.55	0.44	175	400	225	0.034	35
1.50	2.00	2	SD / ND90S	2830	3.18	0.52	80.0	79.0	77.0	0.82	0.77	0.70	250	600	300	0.006	22
		4	SD / ND90L	1415	3.30	1.03	80.0	79.0	77.0	0.79	0.75	0.68	200	550	275	0.019	25
		6	SD / ND100L	935	3.72	1.56	78.0	76.0	73.0	0.72	0.66	0.56	200	500	250	0.030	32
		8	SD / ND112M	700	4.04	2.09	76.0	74.0	71.0	0.68	0.60	0.48	190	400	225	0.057	45
2.20	3.00	2	SD / ND90L	2830	4.61	0.76	81.0	80.0	77.0	0.82	0.76	0.68	250	600	300	0.008	25
		4	SD / ND100L	1430	4.61	1.50	82.0	81.0	78.0	0.81	0.76	0.66	200	600	275	0.030	32
		6	SD / ND112M	935	5.10	2.29	80.0	79.0	75.0	0.75	0.68	0.58	200	500	250	0.048	45
		8	SD / ND132S	710	5.38	3.02	78.0	77.0	74.0	0.73	0.65	0.52	180	450	225	0.174	68
3.70	5.00	2	SD / ND100L	2840	7.25	1.27	84.5	83.5	82.0	0.84	0.80	0.74	250	600	300	0.022	36
		4	SD / ND112M	1430	7.39	2.52	85.0	85.0	83.0	0.82	0.77	0.68	200	600	275	0.052	45
		6	SD / ND132S	940	7.90	3.83	82.5	82.0	80.0	0.79	0.73	0.64	200	550	250	0.174	68
		8	SD / ND132M	710	8.59	5.08	81.0	80.0	78.0	0.74	0.67	0.56	180	450	225	0.214	79
5.50	7.50	2#	ND112M	2880	10.23	1.86	85.0	84.5	82.0	0.88	0.85	0.80	250	650	300	0.034	45
		2	SD / ND132S	2865	10.23	1.87	86.0	85.0	84.0	0.87	0.82	0.78	225	600	300	0.034	42
		4	SD / ND132S	1450	10.35	3.69	86.0	85.0	83.0	0.86	0.82	0.75	225	600	275	0.131	68
		6*	SD / ND132M	950	11.39	5.64	84.0	83.0	81.0	0.80	0.75	0.68	200	550	250	0.214	79
7.50	10.00	2	SD / ND132S	2880	13.55	2.54	87.5	87.0	86.0	0.88	0.85	0.80	250	650	300	0.062	68
		4	SD / ND132M	1455	13.79	5.02	87.0	86.0	84.0	0.87	0.84	0.76	225	600	275	0.161	79
9.30	12.50	2*	ND132M	2890	16.52	3.13	88.0	87.0	85.0	0.89	0.85	0.80	250	700	300	0.076	79.0
		4#	ND132M	1460	17.50	6.25	87.0	87.0	85.5	0.85	0.80	0.73	200	600	275	0.310	82.0

- NOTE :
- 1) EFFICIENCY FIGURES ARE AS PER EFF2 CLASS OF IS 12615-2004
 - 2) ALL PERFORMANCE FIGURES ARE SUBJECT TO TOLERANCES AS PER IS 325 : 1996
- * FOR 45 / 75 °C ONLY
 ** 40/80 °C
 # WITH CLASS F RISE (95°)

EFF Level 2



PERFORMANCE FIGURES OF TEFC SCR MOTORS FOR 50°/70°

OUTPUT		P O L E	FRAME SIZE	FL RPM	FLC AMPS.	FLT Kg-m	EFFICIENCY (%)			POWER FACTOR			DOL STG.		POT % FLT	GD. ² KGM. ²	NET WT. kg
KW	HP						FL	3/4 LOAD	1/2 LOAD	FL	3/4 LOAD	1/2 LOAD	STG.T % FLT	STG.C % FLC			
3.7	5.0	8	ND160M	710	8	5.08	83.0	83.0	81.0	0.74	0.70	0.62	150	500	225	0.46	120
5.5	7.5	6	ND160M	970	11	5.52	86.0	86.0	84.0	0.80	0.76	0.68	200	550	250	0.46	120
		8	ND160M	710	12	7.55	85.0	85.0	83.0	0.74	0.70	0.62	150	500	225	0.46	120
7.5	10.0	6	ND160M	970	15	7.53	87.5	87.0	85.0	0.80	0.76	0.68	175	500	225	0.46	120
		8	ND160L	710	16	10.29	85.0	85.0	83.0	0.76	0.72	0.64	150	500	225	0.64	146
9.3	12.5	2	ND160M	2920	17	3.10	88.0	87.0	85.0	0.88	0.86	0.78	250	600	300	0.13	125
		4	ND160M	1460	17	6.20	88.5	88.5	86.5	0.84	0.81	0.73	175	500	225	0.31	125
		6	ND160L	970	18	9.29	87.5	87.0	84.0	0.80	0.76	0.68	200	550	250	0.59	148
		8	ND180M	720	20	12.58	86.0	86.0	84.0	0.74	0.70	0.60	175	500	225	0.99	174
11	15	2	ND160M	2920	20	3.67	88.5	88.0	86.0	0.88	0.86	0.78	250	600	300	0.13	120
		4	ND160M	1460	21	7.34	89.0	89.0	86.0	0.82	0.79	0.70	200	500	250	0.36	120
		6	ND160L	975	22	10.99	88.0	87.5	86.0	0.80	0.76	0.68	200	550	250	0.64	146
		8	ND180L	720	24	14.88	87.0	87.0	85.0	0.74	0.70	0.60	175	500	225	1.16	205
15	20	2	ND160M	2920	26	5.00	89.5	89.5	87.5	0.88	0.86	0.79	250	650	300	0.17	120
		4*	ND160L	1460	27	10.01	90.0	90.0	88.0	0.85	0.83	0.75	200	500	250	0.47	146
		6	ND180L	975	29	14.98	90.0	90.0	88.0	0.79	0.73	0.66	250	600	300	1.16	205
		8	ND200L	725	33	20.15	88.5	88.5	86.5	0.71	0.65	0.55	225	500	275	2.14	270
18.5	25	2	ND160L	2920	32	6.17	90.0	90.0	88.0	0.88	0.86	0.79	250	650	300	0.21	146
		4	ND180M	1475	33	12.22	91.5	91.5	90.0	0.84	0.80	0.72	200	500	250	0.81	170
		6	ND200L	975	34	18.48	91.1	91.1	89.9	0.84	0.80	0.70	200	550	250	1.69	270
		8	ND225S	725	39	24.85	89.0	89.0	87.0	0.75	0.71	0.63	175	500	225	3.24	345
22	30	2	ND180M	2940	40	7.29	91.0	91.0	89.0	0.84	0.80	0.74	175	500	225	0.44	164
		4	ND180L	1475	40	14.53	92.0	92.0	90.0	0.84	0.80	0.72	200	500	250	0.95	205
		6	ND200L	975	40	21.98	91.5	91.5	90.1	0.84	0.80	0.70	200	500	250	2.04	270
		8	ND225M	725	46	29.56	89.0	89.0	87.0	0.75	0.71	0.63	175	500	225	3.61	375
30	40	2	ND200L	2950	52	9.91	91.5	91.0	89.0	0.87	0.84	0.80	200	600	250	0.80	270
		4	ND200L	1475	53	19.81	92.0	92.0	90.5	0.86	0.82	0.76	225	600	275	1.62	270
		6	ND225M	980	53	29.82	92.0	92.0	90.5	0.85	0.81	0.72	200	550	250	3.61	375
		8	ND250M	735	61	39.76	91.0	90.5	88.5	0.75	0.71	0.63	175	550	225	4.82	465
37	50	2	ND200L	2960	64	12.22	92.5	92.0	90.0	0.87	0.84	0.80	200	500	250	0.89	270
		4	ND225S	1475	63	24.43	92.5	92.5	91.6	0.89	0.86	0.78	200	600	250	2.64	345
		6	ND250M	980	66	36.77	93.0	93.0	92.0	0.84	0.80	0.72	225	600	275	4.82	465
		8	ND280S	735	75	49.03	91.5	91.5	89.5	0.75	0.71	0.63	200	500	250	8.01	600
45	60	2	ND225M	2955	72	14.83	92.5	92.0	90.0	0.94	0.92	0.88	225	650	275	1.87	375
		4	ND225M	1475	76	29.72	93.0	93.0	91.5	0.89	0.86	0.78	200	600	250	3.13	375
		6	ND280S	980	79	44.72	93.0	93.0	91.0	0.85	0.81	0.73	225	600	275	8.01	600
		8	ND280M	725	91	60.46	92.0	92.0	90.5	0.75	0.71	0.63	175	500	225	9.89	630
55	75	2	ND250M	2955	88	18.13	93.0	92.5	90.5	0.94	0.92	0.88	200	600	250	2.79	465
		4	ND250M	1475	92	36.32	93.5	93.5	92.0	0.89	0.86	0.82	200	600	250	3.45	465
		6	ND280M	980	95	54.66	93.5	93.5	92.0	0.86	0.82	0.74	200	650	250	9.89	630
		8	ND315S	740	113.0	72.39	93.0	93.0	91.5	0.73	0.66	0.56	200	550	250	14.1	900
75.0	100.0	2	ND280S	2970	124	24.55	93.6	93.5	92.0	0.90	0.86	0.78	200	600	250	7.14	600
		4	ND280S	1480	123	49.36	94.0	94.0	92.5	0.90	0.88	0.82	200	600	250	7.21	600
		6	ND315S	987	134.0	74.01	93.5	93.0	91.0	0.83	0.76	0.64	200	600	250	14.1	900
		8	ND315M	740	153.0	98.72	93.5	93.5	91.5	0.73	0.66	0.56	200	550	250	19.0	950

- NOTE :
- 1) EFFICIENCY FIGURES ARE AS PER EFF2 CLASS OF IS 12615-2004
 - 2) ALL PERFORMANCE FIGURES ARE SUBJECT TO TOLERANCES AS PER IS 325 : 1996
- * FOR 45 / 75 °C ONLY
 ** 40/80 °C
 # WITH CLASS F RISE (95°)

EFF Level 2



PERFORMANCE FIGURES OF TEFC SCR MOTORS FOR 50°/70°

OUTPUT		P O L E	FRAME SIZE	FL RPM	FLC AMPS.	FLT Kg-m	EFFICIENCY (%)			POWER FACTOR			DOL STG.		POT % FLT	GD. ² KGM. ²	NET WT. kg
KW	HP						FL	3/4 LOAD	1/2 LOAD	FL	3/4 LOAD	1/2 LOAD	STG.T % FLT	STG.C % FLC			
90	120	2	ND280M	2970	148	29.46	94.0	94.0	92.5	0.90	0.86	0.78	200	600	250	8.18	630
		4	ND280M	1480	147	59.21	94.5	94.5	92.5	0.90	0.88	0.82	225	600	275	8.26	630
		6	ND315M	987	156.0	88.79	94.2	94.2	92.5	0.85	0.80	0.70	200	600	250	17.0	950
		8	ND315L	740	180.0	118.43	94.0	94.0	92.0	0.74	0.70	0.60	150	500	225	25.3	1160
110	150	2	ND315S	2965	173.0	36.13	94.0	94.0	92.5	0.94	0.90	0.82	175	600	225	6.6	900
		4	ND315S	1485	176.0	72.13	94.5	94.5	92.0	0.92	0.88	0.80	225	600	275	11.6	900
		6	ND315M	987	188.0	108.52	94.5	94.5	93.0	0.86	0.82	0.74	200	600	250	19.0	950
		8	ND315LX	740	220.0	144.75	94.0	94.0	92.0	0.74	0.70	0.60	150	500	225	29.9	1160
132	180	2	ND315M	2965	207.0	43.35	94.5	94.5	92.5	0.94	0.90	0.82	175	600	225	8.0	950
		4	ND315M	1490	225.0	86.26	95.0	95.0	93.5	0.86	0.82	0.74	225	600	275	14.0	950
		6	ND315L	990	225.0	129.83	95.0	94.5	93.0	0.86	0.82	0.74	200	600	250	25.3	1160
		8	ND315LX	740	263.0	173.70	94.5	94.5	92.5	0.74	0.70	0.60	150	500	225	31.8	1160
150	200	4**	ND315M	1489	255	98.03	95.0	94.0	92.5	0.86	0.82	0.74	160	600	225	15.61	950
160	215	2	ND315LX	2975	249.0	52.37	95.0	94.5	92.5	0.94	0.92	0.90	175	600	225	12.4	1130
		4	ND315LX	1488	260.0	104.70	95.3	95.3	94.0	0.90	0.86	0.78	175	600	225	19.0	1160
		6	ND315LX	990	272.0	157.37	95.0	94.5	93.0	0.86	0.82	0.74	200	600	225	29.9	1160
		8	ND355LX	740	317.0	210.54	95.0	94.0	92.0	0.74	0.70	0.60	150	500	225	36.8	2140
180	240	2	ND315L	2975	280	58.92	95.0	94.5	92.5	0.94	0.92	0.88	225	650	275	13.90	1160
		4	ND315L	1488	292	117.79	95.3	94.8	93.8	0.90	0.88	0.84	175	600	225	21.10	1160
		6	ND355L	990	306	177.05	95.1	95.1	93.5	0.86	0.82	0.76	200	600	250	33.16	2150
		8	ND355LX	742	340	236.22	94.5	94.5	92.0	0.78	0.74	0.66	125	400	225	58.10	2100
200	270	2	ND315LX	2970	310	65.46	95.5	94.5	93.0	0.94	0.92	0.88	175	600	225	16.40	1160
		4	ND315LX	1488	324	130.88	95.5	95.2	94.0	0.90	0.88	0.84	175	600	225	25.00	1160
		6	ND355LX	990	349	196.72	95.0	95.0	93.5	0.84	0.81	0.72	130	500	225	29.70	2150
		8	ND355LX	742	377.0	262.47	94.5	94.5	92.5	0.78	0.74	0.66	125	400	225	58.1	2150
225	300	2**	ND355L	2970	349	73.79	95.5	94.8	93.3	0.94	0.92	0.88	225	600	275	18.40	2150
		4**	ND355L	1489	360	147.24	95.5	94.8	93.4	0.91	0.89	0.85	175	600	225	26.70	2150
		6	ND355LX	991	390	221.31	95.5	95.0	94.0	0.84	0.80	0.70	130	500	225	31.70	2150
		8**	ND355LX	742	423.0	295.28	94.8	94.5	92.5	0.78	0.74	0.66	125	400	225	58.1	2150
250	335	2	ND355LX	2970	387	81.97	95.5	94.8	93.3	0.94	0.92	0.88	150	650	225	27.70	2150
		4	ND355LX	1488	395	163.93	95.7	95.2	93.8	0.92	0.88	0.84	150	600	225	29.60	2150
		6	ND355LX	990	434	245.90	95.5	95.0	94.0	0.84	0.80	0.70	130	500	225	35.60	2150
		8	ND400LX	744	458	327.20	95.0	94.4	92.5	0.80	0.77	0.70	120	400	225	81.80	3200
275	370	2	ND355LX	2980	435	91.49	95.5	94.8	93.3	0.92	0.90	0.86	150	600	225	27.37	2150
		4	ND355LX	1490	440	183.60	95.5	95.0	93.3	0.91	0.88	0.81	140	650	225	31.56	2150
		6	ND355LX	990	477	275.41	95.5	95.0	94.0	0.84	0.80	0.74	160	500	225	39.52	2150
		8	ND400LX	744	503	367.05	95.0	94.4	93.4	0.80	0.77	0.69	120	400	225	81.80	3200
315	425	2	ND355LX	2980	499	102.93	95.5	94.8	92.5	0.92	0.90	0.86	175	600	225	29.60	2150
		4	ND355LX	1490	502	205.86	96.0	95.1	93.6	0.91	0.88	0.82	140	650	225	35.50	2150
		6	ND355LX	995	532	308.58	95.8	95.4	94.0	0.86	0.82	0.77	150	500	225	42.40	2150
		8*	ND400LX	744	588	412.28	95.5	95.0	94.0	0.78	0.75	0.66	120	400	225	97.60	3200
335	452	2**	ND355LX	2980	530	109.49	95.5	94.8	92.5	0.92	0.90	0.88	175	600	225	29.79	2150
		4	ND355LX	1493	534	218.55	96.0	95.4	93.8	0.91	0.88	0.82	150	600	200	38.06	2150
360	483	4	ND355LX	1492	567	235.01	96.0	95.6	94.0	0.92	0.90	0.88	150	600	225	38.06	2150
		6	ND400LX	995	609	352.40	95.6	94.6	93.1	0.86	0.82	0.72	140	550	225	81.80	3200

- NOTE : 1) EFFICIENCY FIGURES ARE AS PER EFF2 CLASS OF IS 12615-2004
 2) ALL PERFORMANCE FIGURES ARE SUBJECT TO TOLERANCES AS PER IS 325 : 1996
 * FOR 45 / 75 °C ONLY
 ** 40/80 °C
 # WITH CLASS F RISE (95°)
Frame 450 under development. Refer enquiries to Division



OUTLINE DIMENSIONS OF AC SCR TEFC FLANGE MOUNTED ALUMINIUM BODY METRIC MOTORS

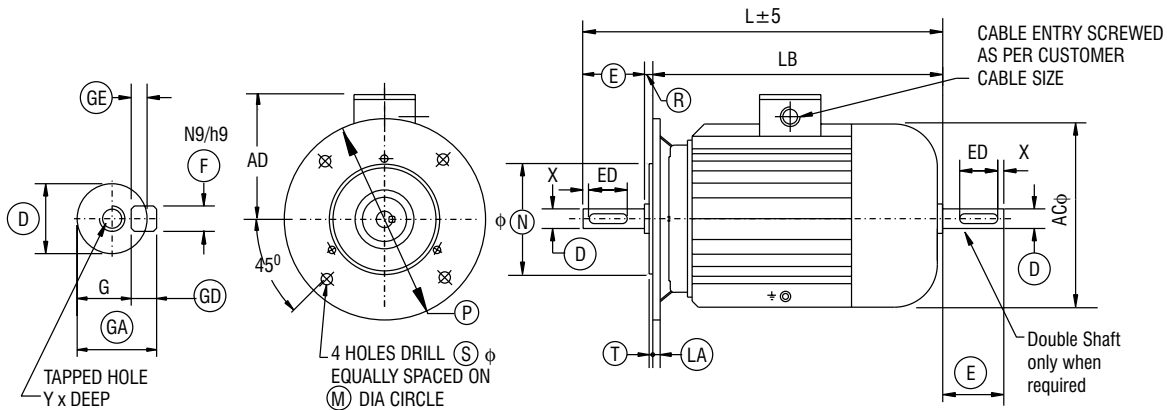

FRAME	FLANGE FIXING							SHAFT AND KEY									YxDEEP	OVERALL (MAX)			
	SIZE	M	N	P	R	S	T	LA	D	E	ED	F	G	GA	GD	GE		X	AC	L	LB
SD63	115	95	140	0	10	3	9	11	23	18	4	8.5	12.5	4	2.5	2.5	M4x10	125	220	197	100
SD71	130	110	160	0	10	3.5	9	14	30	25	5	11	16	5	3	2.5	M5x12.5	145	250	220	100
SD80	165	130	200	0	12	3.5	10	19	40	27	6	15.5	21.5	6	3.5	-	M6x16	165	285	245	120
SD90S	165	130	200	0	12	3.5	10	24	50	36	8	20	27	7	4	-	M8x19	180	310	260	140
SD90L																			335	285	
SD100L	215	180	250	0	15	4	11	28	60	44	8	24	31	7	4	-	M10x22	200	360	300	150
SD112M																			222	380	
SD132S	265	230	300	0	15	4	10	19	40	27	6	15.5	21.5	6	3.5	-	M6x16	165	285	245	120
SD132M	165	130	200	0	15	4	10	19	40	27	6	15.5	21.5	6	3.5	-	M6x16	165	285	245	120

OUTLINE DIMENSIONS OF AC SCR TEFC FOOT MOUNTED ALUMINIUM BODY METRIC MOTORS

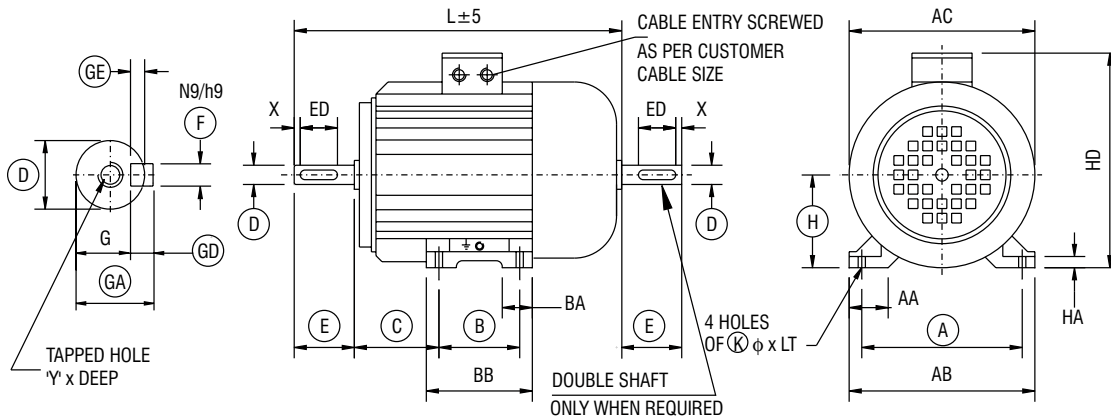

FRAME	FOOT FIXING											SHAFT AND KEY									YxDEEP	OVERALL (MAX)		
	SIZE	A	B	C	H	AA	AB	BA	BB	HA	K	LT	D	E	ED	F	G	GA	GD	GE		X	AC	L
SD63	100	80	40	63	25.5	122	30	96	9	7	-	11	23	18	4	8.5	12.5	4	2.5	2.5	M4 x 10	125	210	160
SD71	112	90	45	71	30	136	30	110	9	7	-	14	30	25	5	11	16	5	3	2.5	M5x12.5	145	250	170
SD80	125	100	50	80	28	152	35	125	11	10	14	19	40	27	6	15.5	21.5	6	3.5	-	M6x16	165	285	200
SD90S	140	100	56	90	40	170	30	126	13	10	15	24	50	36	8	20	27	7	4	-	M8x19	180	310	226
SD90L		151						335																
SD100L	160	140	63	100	48	192	35	170	13	12	16	28	60	44	8	24	31	7	4	-	M10x22	200	360	245
SD112M	190	140	70	112	50	222	35	170	13	12	16	28	60	44	8	24	31	7	4	-	M10x22	222	380	270
SD132S	216	140	89	132	52	252	55	178	13	12	16	38	80	60	10	33	41	8	5	-	M12x28	260	475	310
SD132M		216																						



OUTLINE DIMENSION DRAWING FOR 3 PHASE SQUIRREL CAGE TEFC FOOT MOUNTED INDUCTION MOTORS (4 POLE & UP ALL FRAMES & 2 POLE & UP, UPTO ND200L FRAME)

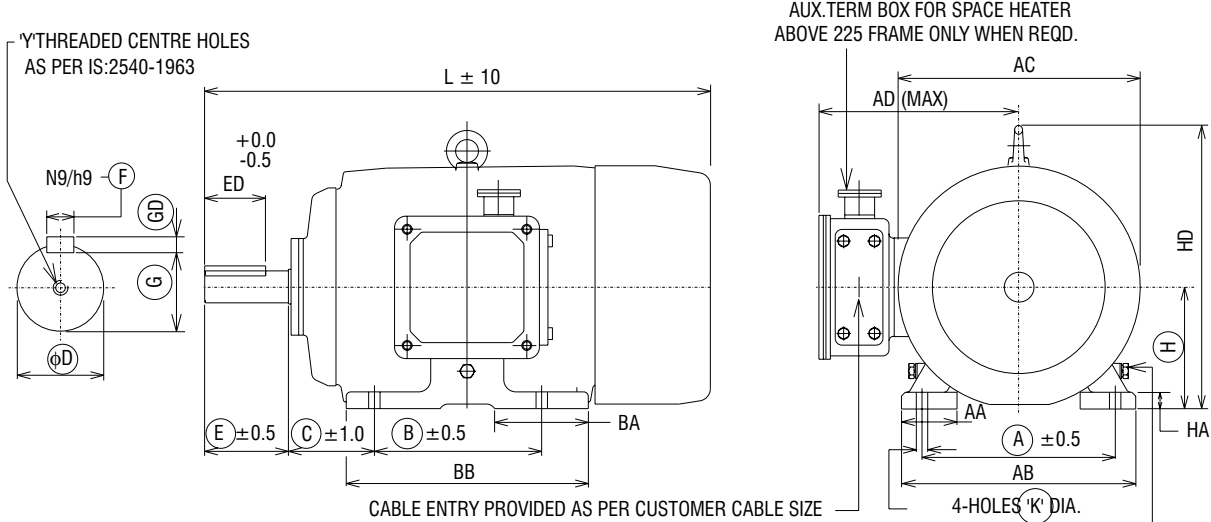

RINGED DIMENSIONS ARE AS PER IS:1231
ALL DIMENSIONS ARE IN mm

EARTHING TERMINALS OF M6 FOR 80-132 FRAMES.
M8 FOR 160-225 FRAMES.
M12 FOR 250-355 FRAMES

Frame	A	B	C	H	AA	AB	BA	BB	K	D	E	ED	F	GD	G	Y	AD	AC	L	HD	HA
ND80	125	100	50	80.0/ 79.7	35	152	45	124	10.0/ 10.5	19.009/ 18.996	40	27	6.00/ 5.97	6.00/ 5.91	15.5/ 15.3	M6X16	134	170	285	165	11
ND90S	140	100	56	90.0/ 89.7	35	168	40	127	10.0/ 10.5	24.009/ 23.996	50	36	8.00/ 7.964	7.00/ 6.91	20.0/ 19.8	M8X19	150	195	310	185	13
ND90L	140	125	56	90.0/ 89.7	35	168	52	152	10.0/ 10.5	24.009/ 23.996	50	36	8.00/ 7.964	7.00/ 6.91	20.0/ 19.8	M8X19	150	195	335	185	13
ND100L	160	140	63	100.0/ 99.7	36	192	45	170	12.0/ 12.5	28.009/ 27.996	60	44	8.00/ 7.957	7.0/ 6.91	24.0/ 23.8	M10X22	160	215	380	250	13
ND112M	190	140	70	112.0/ 111.7	36	222	60	170	12.0/ 12.5	28.009/ 27.996	60	44	8.00/ 7.957	7.0/ 6.91	24.0/ 23.8	M10X22	170	235	405	275	13
ND132S	216	140	89	132.0/ 131.7	48	254	54	178	12.0/ 12.5	38.018/ 38.002	80	60	10.0/ 9.957	8.0/ 7.91	33.0/ 32.8	M12X28	190	275	470	320	16
ND132M	216	178	89	132.0/ 131.7	48	254	54	216	12.0/ 12.5	38.018/ 38.002	80	60	10.0/ 9.957	8.0/ 7.91	33.0/ 32.8	M12X28	190	275	510	320	16
ND160M	254	210	108	160.0/ 159.5	73	308	76	254	15.5/ 15.0	42.018/ 42.002	110	80	12.00/ 11.957	8.00/ 7.91	37.0/ 36.8	M16X32	325	318	605	376	22
ND160L	254	254	108	160.0/ 159.5	73	308	101	298	15.5/ 15.0	42.018/ 42.002	110	80	12.00/ 11.957	8.00/ 7.91	37.0/ 36.8	M16X32	325	318	650	376	22
ND180M	279	241	121	180/ 179.5	84	348	85	286	15.5/ 15.0	48.018/ 48.002	110	80	14.00/ 13.957	9.00/ 8.91	42.5/ 42.3	M16X32	345	352	677	418	22
ND180L	279	279	121	180/ 179.5	84	348	106	323	15.5/ 15.0	48.018/ 48.002	110	80	14.00/ 13.957	9.00/ 8.91	42.5/ 42.3	M16X32	345	352	715	418	22
ND200L	318	305	133	200.0/ 199.5	66	381	115	356	19.5/ 19.0	55.030/ 55.011	110	80	16.00/ 15.957	10.00/ 9.91	49.0/ 48.8	M20X40	430	428	790	480	25
ND225S	356	286	149	225.0/ 224.5	70	425	102	340	19.5/ 19.0	60.030/ 60.011	140	110	18.00/ 17.957	11.00/ 10.91	53.0/ 52.8	M20X40	455	470	840	534	25
ND225M	356	311	149	225.0/ 224.5	70	425	102	375	19.5/ 19.0	60.030/ 60.011	140	110	18.00/ 17.957	11.00/ 10.91	53.0/ 52.8	M20X40	455	470	865	534	25
ND250S	406	311	168	250.0/ 249.5	80	483	140	419	24.5/ 24.0	65.030/ 65.011	140	110	18.00/ 17.957	11.00/ 10.91	58.0/ 57.8	M20X40	485	500	940	598	32
ND250M	406	349	168	250.0/ 249.5	80	483	140	419	24.5/ 24.0	65.030/ 65.011	140	110	18.00/ 17.957	11.00/ 10.91	58.0/ 57.8	M20X40	485	500	940	598	32
ND280S	457	368	190	280.0/ 279.0	100	538	137	440	24.5/ 24.0	75.030/ 75.011	140	110	20.00/ 19.948	12.00/ 11.91	67.5/ 67.3	M20X40	530	536	1035	642	35
ND280M	457	419	190	280.0/ 279.0	100	538	162	487	24.5/ 24.0	75.030/ 75.011	140	110	20.00/ 19.948	12.00/ 11.91	67.5/ 67.3	M20X40	530	536	1085	642	35
ND315S	508	406	216	315.0/ 314.0	110	597	138	485	28.5/ 28.0	80.030/ 80.011	170	140	22.00/ 21.948	14.00/ 13.91	71.0/ 70.8	M20X40	530	590	1180	725	35
ND315M	508	457	216	315.0/ 314.0	110	597	164	533	28.5/ 28.0	80.030/ 80.011	170	140	22.00/ 21.948	14.00/ 13.91	71.0/ 70.8	M20X40	530	590	1230	725	35
ND315L	508	508	216	315.0/ 314.0	110	610	204	655	28.5/ 28.0	90.035/ 90.013	170	140	25.00/ 24.948	14.00/ 13.91	81.0/ 80.8	M24X50	570	655	1295	755	38
ND315LX	508	508	216	315.0/ 314.0	110	610	235	740	28.5/ 28.0	90.035/ 90.013	170	140	25.00/ 24.948	14.00/ 13.91	81.0/ 80.8	M24X50	570	655	1390	755	38
ND355S	610	510	254	355.0/ 354.0	110	710	253	745	28.5/ 28.0	100.035/ 100.013	210	160	28.00/ 27.948	16.00/ 15.89	90.0/ 89.8	M24X50	560	672	1513	780	40
ND355M	610	560	254	355.0/ 354.0	110	710	253	745	28.5/ 28.0	100.035/ 100.013	210	160	28.00/ 27.948	16.00/ 15.89	90.0/ 89.8	M24X50	560	672	1513	780	40
ND355L	610	630	254	355.0/ 354.0	110	710	253	745	28.5/ 28.0	100.035/ 100.013	210	160	28.00/ 27.948	16.00/ 15.89	90.0/ 89.8	M24X50	560	672	1513	780	40

EFF Level 2



OUTLINE DIMENSION DRAWING FOR 3 PHASE SQUIRREL CAGE TEFC FOOT MOUNTED INDUCTION MOTORS (2 POLE)

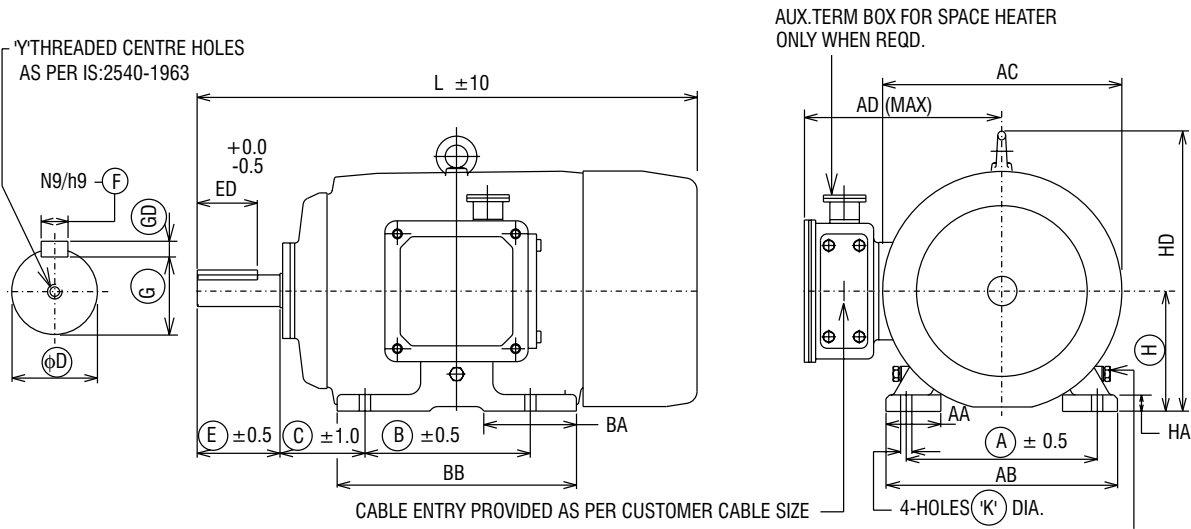

RINGED DIMENSIONS ARE AS PER IS:1231
ALL DIMENSIONS ARE IN mm

EARTHING TERMINALS OF M8 FOR 225 FRAME
M12 FOR 250-355 FRAMES

Frame	A	B	C	H	AA	AB	BA	BB	K	D	E	ED	F	GD	G	Y	AD	AC	L	HD	HA
ND225S	356	286	149	225.0 / 224.5	70	425	102	340	19.5 / 19.0	55.030 / 55.011	110	80	16.00 / 15.957	10.00 / 9.91	49.0 / 48.8	M20X40	455	470	810	534	25
ND225M	356	311	149	225.0 / 224.5	70	425	102	375	19.5 / 19.0	55.030 / 55.011	110	80	16.00 / 15.957	10.00 / 9.91	49.0 / 48.8	M20X40	455	470	825	534	25
ND250S	406	311	168	250.0 / 249.5	80	483	140	419	24.5 / 24.0	60.030 / 60.011	140	110	18.00 / 17.957	11.00 / 10.91	53.0 / 52.8	M20X40	485	500	940	598	32
ND250M	406	349	168	250.0 / 249.5	80	483	140	419	24.5 / 24.0	60.030 / 60.011	140	110	18.00 / 17.957	11.00 / 10.91	53.0 / 52.8	M20X40	485	500	940	598	32
ND280S	457	368	190	280.0 / 279.0	100	538	137	440	24.5 / 24.0	65.030 / 65.011	140	110	18.00 / 17.957	11.00 / 10.91	58.0 / 57.8	M20X40	530	536	1035	642	35
ND280M	457	419	190	280.0 / 279.0	100	538	162	487	24.5 / 24.0	65.030 / 65.011	140	110	18.00 / 17.957	11.00 / 10.91	58.0 / 57.8	M20X40	530	536	1085	642	35
ND315S	508	406	216	315.0 / 314.0	110	597	138	485	28.5 / 28.0	65.030 / 65.011	140	110	18.00 / 17.957	11.00 / 10.91	58.0 / 57.8	M20X40	530	590	1150	725	35
ND315M	508	457	216	315.0 / 314.0	110	597	164	533	28.5 / 28.0	65.030 / 65.011	140	110	18.00 / 17.957	11.00 / 10.91	58.0 / 57.8	M20X40	530	590	1200	725	35
ND315L	508	508	216	315.0 / 314.0	110	610	204	655	28.5 / 28.0	70.030 / 70.011	140	110	20.00 / 19.948	12.00 / 11.91	62.5 / 62.3	M20X40	570	655	1265	755	38
ND315LX	508	508	216	315.0 / 314.0	110	610	235	740	28.5 / 28.0	70.030 / 70.011	140	110	20.00 / 19.948	12.00 / 11.91	62.5 / 62.3	M20X40	570	655	1360	755	38
ND355S	610	510	254	355.0 / 354.0	110	710	253	745	28.5 / 28.0	75.030 / 75.011	170	140	20.00 / 19.948	12.00 / 11.91	67.5 / 67.3	M20X40	560	672	1473	780	40
ND355M	610	560	254	355.0 / 354.0	110	710	253	745	28.5 / 28.0	75.030 / 75.011	170	140	20.00 / 19.948	12.00 / 11.91	67.5 / 67.3	M20X40	560	672	1473	780	40
ND355L	610	630	254	355.0 / 354.0	110	710	253	745	28.5 / 28.0	75.030 / 75.011	170	140	20.00 / 19.948	12.00 / 11.91	67.5 / 67.3	M20X40	560	672	1473	780	40

EFF Level 2



OUTLINE DIMENSION DRAWING FOR 3 PHASE SQUIRREL CAGE TEFC FOOT MOUNTED TB ON RHS INDUCTION MOTORS (FRAME ND355LX)

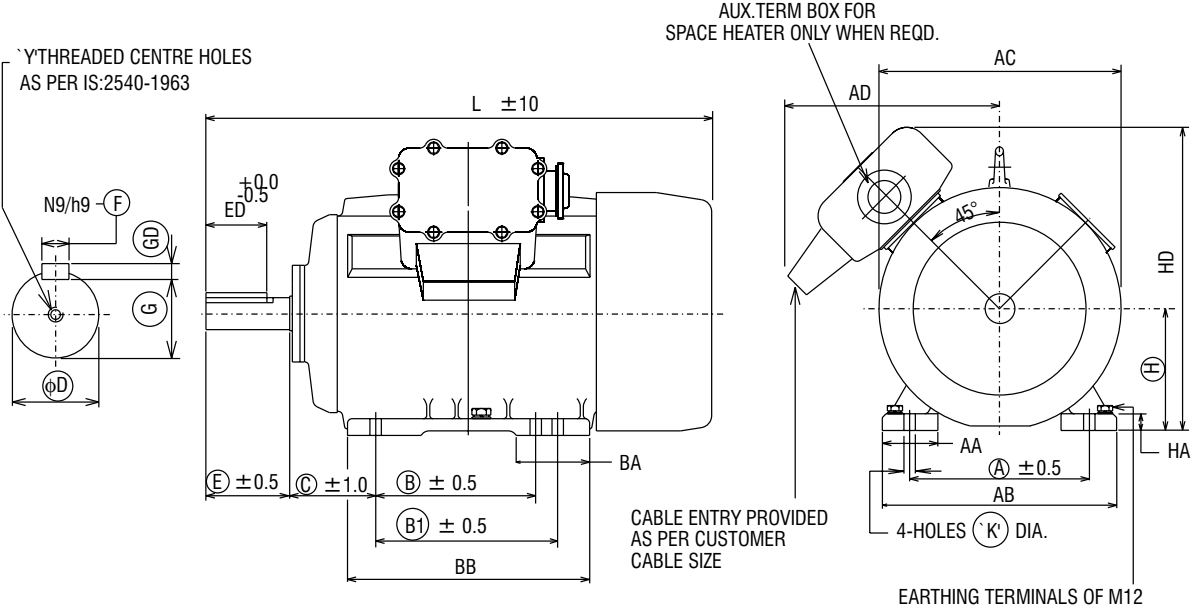

RINGED DIMENSIONS ARE AS PER IS:1231
ALL DIMENSIONS ARE IN mm

Frame	A	B	C	H	AA	AB	BA	BB	K	D	E	ED	F	GD	G	Y	AD	AC	L	HD	HA
2 POLE																					
ND355LX	610	630	254	355.0 / 354.0	110	710	250	850	28.5 / 28.0	75.030 / 75.011	170	140	20.00 / 19.948	12.00 / 11.91	67.5 / 67.3	M20x40	720	720	1540	950	40
4 POLE & UP																					
ND355LX	610	630	254	355.0 / 354.0	110	710	250	850	28.5 / 28.0	100.035 / 100.013	210	160	28.00 / 27.948	16.00 / 15.89	90.0 / 89.8	M24x50	720	720	1580	950	40

EFF Level 2



OUTLINE DIMENSION DRAWING FOR 3 PHASE SQUIRREL CAGE TEFC FLANGE MOUNTED INDUCTION MOTORS (4 POLE & UP ALL FRAMES & 2 POLE & UP, UPTO ND200L FRAME)

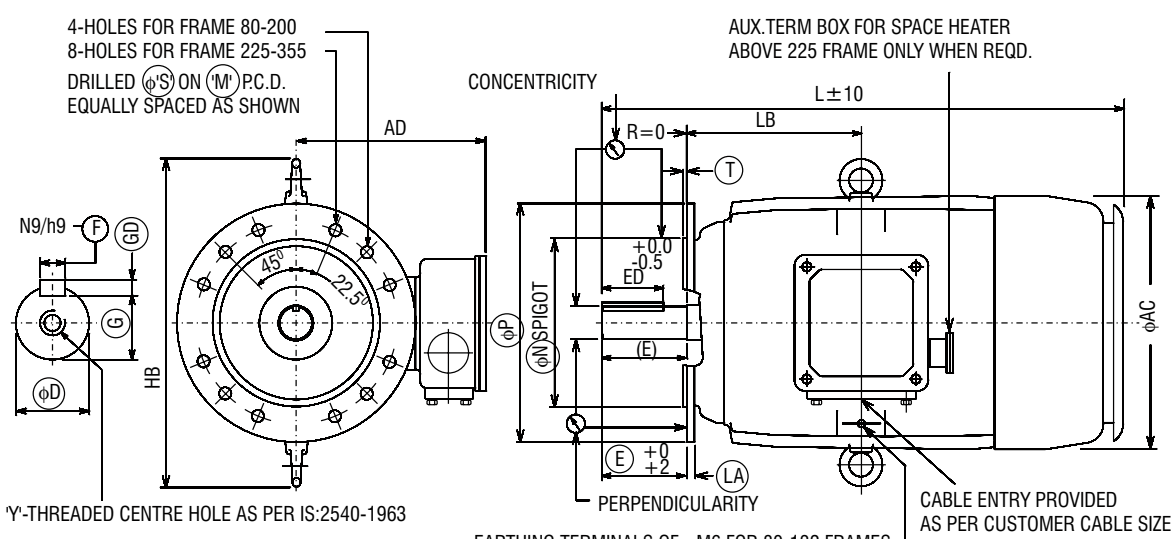

RINGED DIMENSIONS ARE AS PER IS:2223
ALL DIMENSIONS ARE IN mm

Frame	D	E	ED	F	GD	G	Y	AD	AC	L	MTol	NTol	P	S	T	LA	LB	HB
ND80	19.009 / 18.996	40	27	6.00 / 5.97	6.00 / 5.91	15.5 / 15.3	M6X16	134	170	325	165.3 / 164.7	130.014 / 129.989	200	12	3.5	10	100	260
ND90S	24.009 / 23.996	50	36	8.00 / 7.964	7.00 / 6.91	20.0 / 19.8	M8X19	150	195	375	165.3 / 164.7	130.014 / 129.989	200	12	3.5	10	122	280
ND90L	24.009 / 23.996	50	36	8.00 / 7.964	7.00 / 6.91	20.0 / 19.8	M8X19	150	195	400	165.3 / 164.7	130.014 / 129.989	200	12	3.5	10	137	280
ND100L	28.009 / 27.996	60	44	8.00 / 7.957	7.0 / 6.91	24.0 / 23.8	M10X22	160	215	440	215.3 / 214.7	180.016 / 179.987	250	15	4	11	137	300
ND112M	28.009 / 27.996	60	44	8.00 / 7.957	7.0 / 6.91	24.0 / 23.8	M10X22	170	235	465	215.3 / 214.7	180.016 / 179.987	250	15	4	11	140	320
ND132S	38.018 / 38.002	80	60	10.0 / 9.957	8.0 / 7.91	33.0 / 32.8	M12X28	190	275	542	265.3 / 264.7	230.016 / 229.987	300	15	4	14	158	380
ND132M	38.018 / 38.002	80	60	10.0 / 9.957	8.0 / 7.91	33.0 / 32.8	M12X28	190	275	580	265.3 / 264.7	230.016 / 229.987	300	15	4	14	177	380
ND160M	42.018 / 42.002	110	80	12.00 / 11.957	8.00 / 7.91	37.0 / 36.8	M16X32	325	318	660	300.5 / 299.5	250.016 / 249.987	350	19	5	18	213	421
ND160L	42.018 / 42.002	110	80	12.00 / 11.957	8.00 / 7.91	37.0 / 36.8	M16X32	325	318	705	300.5 / 299.5	250.016 / 249.987	350	19	5	18	235	421
ND180M	48.018 / 48.002	110	80	14.00 / 13.957	9.00 / 8.91	42.5 / 42.3	M16X32	345	352	750	300.5 / 299.5	250.016 / 249.987	350	19	5	18	242	478
ND180L	48.018 / 48.002	110	80	14.00 / 13.957	9.00 / 8.91	42.5 / 42.3	M16X32	345	352	790	300.5 / 299.5	250.016 / 249.987	350	19	5	18	260	478
ND200L	55.030 / 55.011	110	80	16.00 / 15.957	10.00 / 9.91	49.0 / 48.8	M20X40	430	428	830	350.5 / 349.5	300.018 / 299.982	400	19	5	18	285	557
ND225S	60.030 / 60.011	140	110	18.00 / 17.957	11.00 / 10.91	53.0 / 52.8	M20X40	455	470	895	400.5 / 399.5	350.018 / 349.982	450	19	5	19	305	618
ND225M	60.030 / 60.011	140	110	18.00 / 17.957	11.00 / 10.91	53.0 / 52.8	M20X40	455	470	895	400.5 / 399.5	350.018 / 349.982	450	19	5	19	305	618
ND250S	65.030 / 65.011	140	110	18.00 / 17.957	11.00 / 10.91	58.0 / 57.8	M20X40	485	500	1020	500.5 / 499.5	450.020 / 449.980	550	19	5	22	342	688
ND250M	60.030 / 60.011	140	110	18.00 / 17.957	11.00 / 10.91	58.0 / 57.8	M20X40	485	500	1020	500.5 / 499.5	450.020 / 449.980	550	19	5	22	342	688
ND280S	75.030 / 75.011	140	110	20.00 / 19.948	12.00 / 11.91	67.5 / 67.3	M20X40	530	536	1170	500.5 / 499.5	450.020 / 449.980	550	19	5	22	400	722
ND280M	75.030 / 75.011	140	110	20.00 / 19.948	12.00 / 11.91	67.5 / 67.3	M20X40	530	536	1170	500.5 / 499.5	450.020 / 449.980	550	19	5	22	400	722
ND315S	80.030 / 80.011	170	140	22.00 / 21.948	14.00 / 13.91	71.0 / 70.8	M20X40	530	590	1325	601.0 / 599.0	550.022 / 549.978	660	24	6	25	445	812
ND315M	80.030 / 80.011	170	140	22.00 / 21.948	14.00 / 13.91	71.0 / 70.8	M20X40	530	590	1325	601.0 / 599.0	550.022 / 549.978	660	24	6	25	445	812
ND315L	90.035 / 90.013	170	140	25.00 / 24.948	14.00 / 13.91	81.0 / 80.8	M24X50	570	655	1495	601.0 / 599.0	550.022 / 549.978	660	24	6	25	531	880
ND315LX	90.035 / 90.013	170	140	25.00 / 24.948	14.00 / 13.91	81.0 / 80.8	M24X50	570	655	1495	601.0 / 599.0	550.022 / 549.978	660	24	6	25	531	880
ND355S	100.035 / 100.013	210	160	28.00 / 27.948	16.00 / 15.89	90.0 / 89.8	M24X50	570	672	1650	741.0 / 739.0	680.025 / 679.975	800	24	6	28	570	900
ND355M	100.035 / 100.013	210	160	28.00 / 27.948	16.00 / 15.89	90.0 / 89.8	M24X50	570	672	1650	741.0 / 739.0	680.025 / 679.975	800	24	6	28	570	900
ND355L	100.035 / 100.013	210	160	28.00 / 27.948	16.00 / 15.89	90.0 / 89.8	M24X50	570	672	1650	741.0 / 739.0	680.025 / 679.975	800	24	6	28	570	900

EFF Level 2



OUTLINE DIMENSION DRAWING FOR 3 PHASE SQUIRREL CAGE TEFC FLANGE MOUNTED INDUCTION MOTORS (2 POLE)

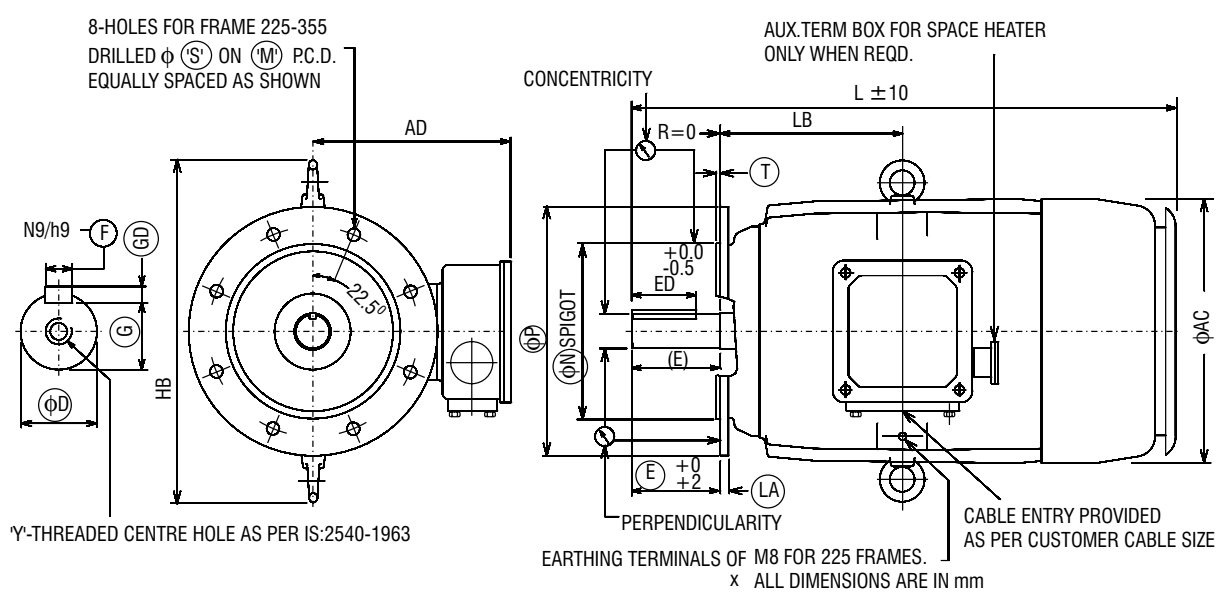

RINGED DIMENSIONS ARE AS PER IS:2223
ALL DIMENSIONS ARE IN mm

Frame	D	E	ED	F	GD	G	Y	AD	AC	L	MTol	NTol	P	S	T	LA	LB	HB
2 POLE																		
ND225S	55.030 / 55.011	110	80	16.00 / 15.957	10.0 / 9.91	49.0 / 48.8	M20X40	455	470	865	400.5 / 399.5	350.018 / 349.982	450	19	5	19	305	618
ND225M	55.030 / 55.011	110	80	16.00 / 15.957	10.0 / 9.91	49.0 / 48.8	M20X40	455	470	865	400.5 / 399.5	350.018 / 349.982	450	19	5	19	305	618
ND250S	60.030 / 60.011	140	110	18.00 / 17.957	11.00 / 10.91	53.0 / 52.8	M20X40	485	500	1020	500.5 / 499.5	450.020 / 449.980	550	19	5	22	343	688
ND250M	60.030 / 60.011	140	110	18.00 / 17.957	11.00 / 10.91	53.0 / 52.8	M20X40	485	500	1020	500.5 / 499.5	450.020 / 449.980	550	19	5	22	343	688
ND280S	65.030 / 65.011	140	110	18.00 / 17.957	11.00 / 10.91	58.0 / 57.8	M20X40	530	536	1170	500.5 / 499.5	450.020 / 449.980	550	19	5	22	400	722
ND280M	65.030 / 65.011	140	110	18.00 / 17.957	11.00 / 10.91	58.0 / 57.8	M20X40	530	536	1170	500.5 / 499.5	450.020 / 449.980	550	19	5	22	400	722
ND315S	65.030 / 65.011	140	110	18.00 / 17.957	11.00 / 10.91	58.0 / 57.8	M20X40	530	590	1295	601.0 / 599.0	550.022 / 549.978	660	24	6	25	445	812
ND315M	65.030 / 65.011	140	110	18.00 / 17.957	11.00 / 10.91	58.0 / 57.8	M20X40	530	590	1295	601.0 / 599.0	550.022 / 549.978	660	24	6	25	445	812
ND315L	70.030 / 70.011	140	110	20.00 / 19.948	12.00 / 11.91	62.5 / 62.3	M20X40	570	655	1460	601.0 / 599.0	550.022 / 549.948	660	24	6	25	530	880
ND315LX	70.030 / 70.011	140	110	20.00 / 19.948	12.00 / 11.91	62.5 / 62.3	M20X40	570	655	1460	601.0 / 599.0	550.022 / 549.948	660	24	6	25	530	880
ND355S	75.030 / 75.011	170	140	20.00 / 19.948	12.00 / 11.91	67.5 / 67.3	M20X40	720	720	1610	741.0 / 739.0	680.025 / 679.975	800	24	6	28	570	900
ND355M	75.030 / 75.011	170	140	20.00 / 19.948	12.00 / 11.91	67.5 / 67.3	M20X40	720	720	1610	741.0 / 739.0	680.025 / 679.975	800	24	6	28	570	900
ND355L	75.030 / 75.011	170	140	20.00 / 19.948	12.00 / 11.91	67.5 / 67.3	M20X40	720	720	1610	741.0 / 739.0	680.025 / 679.975	800	24	6	28	570	900



OUTLINE DIMENSION DRAWING FOR 3 PHASE SQUIRREL CAGE TEFC FLANGE MOUNTED INDUCTION MOTORS (FRAME ND355LX)

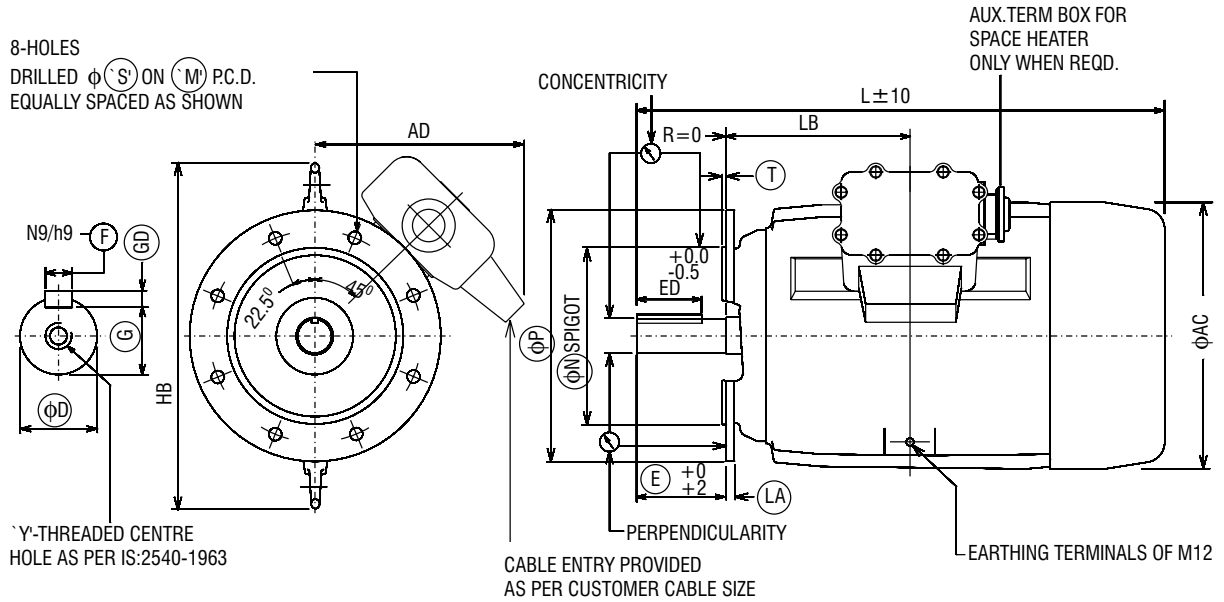

RINGED DIMENSIONS ARE AS PER IS:2223
ALL DIMENSIONS ARE IN mm

Frame	D	E	ED	F	GD	G	Y	AD	AC	L	MTol	NTol	P	S	T	LA	LB	HB
2 POLE																		
ND355LX	75.030/ 75.011	170	140	20.00/ 19.948	12.00/ 11.91	67.5/ 67.3	M20X40	720	720	1540	741.0/ 739.0	680.025/ 679.975	800	24	6	28	570	900
4 POLE & UP																		
ND355LX	100.035/ 100.013	210	160	28.00/ 27.948	16.00/ 15.89	90.0/ 89.8	M24X50	720	720	1580	741.0/ 739.0	680.025/ 679.975	800	24	6	28	570	900

EFF Level 2



DIMENSION DRAWING FOR 3 PHASE TEFC SQUIRREL CAGE FOOT MOUNTED INDUCTION MOTORS (FRAME : ND400 LX)

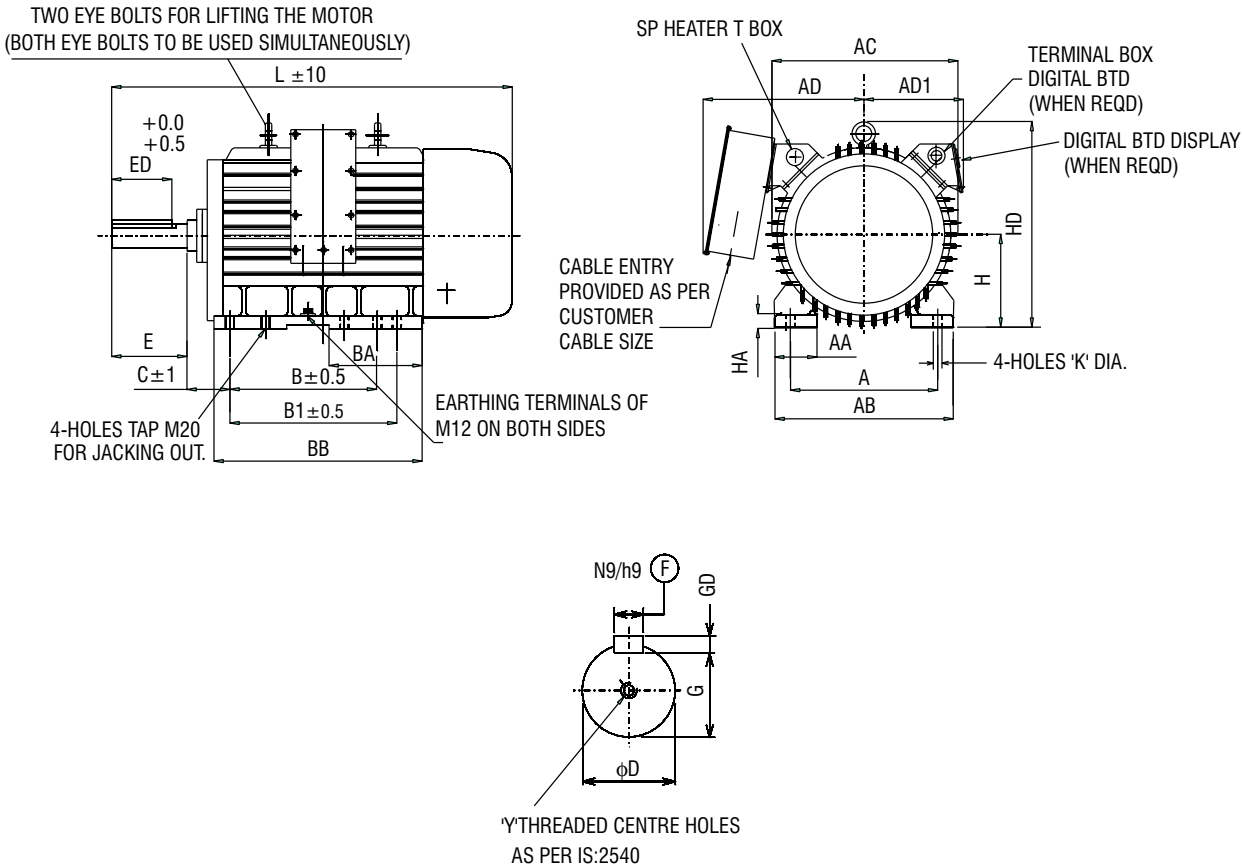

ALL DIMENSIONS ARE IN mm

FRAME SIZE	FOOT FIXING										SHAFT AND KEY *						OVERALL						
	A	B	B1	C	H TOL	AA	AB	BA	BB	K TOL	D TOL	E	ED	F TOL	GD TOL	G	Y	AD	AD1	AC	L	HD	HA
ND400LX 4P & UP	686	800	900	280	400 399	195	845	400	1057	35.0 34.5	100.035 100.013	210	160	28.00 27.948	16.00 15.89	90.0 89.8	M24x50	800	521	875	1855	980	45

MACHINES RUNNING AT 3000 RPM HAVE SMALLER SHAFTS AS SHOWN HERE	FRAME	D TOL	E	ED	F TOL	GD TOL	G	L
	ND400LX	85.035				22.00	14.00	76.0
2 POLE	85.013		170	140	21.95	13.91	75.8	1870

Northern Region Sales Office :

New Delhi :

Vandana, 11, Tolstoy Marg, New Delhi - 110 001
Phones : (011) 30416300

Jalandhar :

416-417, 3rd Floor, Prestige Chambers,
GT Road, Jalandhar - 144 001
Phones : (0181) 3240990

Lucknow :

Saran Chambers II, 3rd Floor, 5 Park Road,
Lucknow - 226 001
Phones : (0522) 3018850

Jaipur :

Church Road, P. O. Box. No. 173, Jaipur-302 001
Phones : (0141) 3018800

Eastern Region Sales Office :

Kolkata :

50, Chowringhee Road, Kolkata - 700 071
Phones : (033) 22829681-85

Bhubaneshwar :

Janpath Tower, Third Floor,
Ashok Nagar, Unit II,
Bhubaneshwar - 751 009
Phones : (0674) 2531128

Western Region Sales Office :

Mumbai :

Kanjur Marg (E), Mumbai-400 042.
Phones : (022) 67558000

Ahmedabad :

909-916, Sakar II, Near Ellis Bridge Police Station,
Ahmedabad - 380 006
Phones : (079) 40012000

Pune :

Premium Point, 4th Floor, Opp. Modern High School,
Jangali Maharaj Road, Pune 5.
Phones : (020) 25534675-77

Indore :

103-B, Apollo Trade Centre, 2B, Rajgarh Kothi,
Mumbai-Agra Road, Indore - 452 001.
Phones : (0731) 2498269

Nagpur :

3, West High Court Road, Lal Bahadur Shastri Chowk,
Dharampath, Nagpur - 440 010
Phones : (0712) 2531271

Raipur :

5, New Tilak Nagar, Near Sai Care Hospital,
Avanthi Bihar Colony, Raipur.
Phones : (0771) 4022215

Southern Region Sales Office :

Chennai :

No.3-A, MGR Salai, Kodambakkam High Road,
Nungambakkam,
Chennai - 600 034.
Phones : (044) 42247500

Bangalore :

1st Floor, Janardhana Towers, 562/640,
Bannerghetta Road, Bilekahalli, Bangalore 560 076.
Phones : (080) 41391908

Cochin :

Cherupushpam Building, 5th Floor, 300-6
Shanmugham Road, Ernakulum, Cochin - 682 031.
Phones : (0484) 2370860

Secunderabad :

4th Floor, Minerva House, 94, Sarojini Devi Road,
Secunderabad - 500 003.
Phones : (040) 40002300

Regional Service Centres :

North : Vandana, 11, Tolstoy Marg, New Delhi-110 001. Phones: (011) 30416308.

East : 21, R.N.Mukherjee Road, Kolkata-700 001. Phones: (033) 22489160.

West : Kanjur Marg (E), Mumbai 400 042. Phones : (022) 67558590.

South : 3A, MGR Salai, Kodambakkam High Road, Nungambakkam, Chennai-600 034. Phones : (044) 23651369.

NOTE : As the design and manufacture of Crompton Greaves electrical equipment are subject to constant improvement,, the product supplied may differ in some details from the specifications and illustrations given in this booklet.
For more details, contact Works.

Crompton Greaves Limited

LT Motors Division

Manufacturing Units :

Ahmednagar Works :

A-6/2, M.I.D.C. Industrial Area, Ahmednagar - 414 111.

Tel.: (0241) 2776 150 - 157. Fax : (0241) 2777508, 2777800.

Goa Works :

S-14/15, Colvale Industrial Estate, Colvale, Bardez, Goa - 403 513.

Tel.: (0832) 2299664 / 665 / 666 Fax: (0832) 2299663.

Registered Office :

CG House, 6th Floor, Dr. Annie Besant Road, Worli, Mumbai - 400 030. India.

W : www.cgglobal.com